

SOLAR RADIATION SENSOR

STANDARD, INDUSTRIAL, &
VANTAGE PRO VERSIONS

The Davis Solar Radiation Sensor is a precision instrument that detects radiation at wavelengths of 300 to 1100 nanometers. The spectral response of the silicon photodiode detector is a good match to the spectrum of solar irradiance.

Avoid touching the small white diffuser at the top of the sensor. Any skin oil on this surface will degrade the sensitivity of the sensor. To remove any oil present, clean the diffuser with a clean swab and ethyl (denatured) alcohol. Do NOT use rubbing alcohol.

The sensor is made up of the following components:

◆ **Shield**

The outer shell shields the sensor body from thermal radiation and provides a path for convection cooling of the body, minimizing heating of the sensor interior. It provides a cutoff ring for cosine response, a level indicator, and fins to aid in aligning the sensor with the sun's rays.

◆ **Body**

The body houses the following components:

◆ **Diffuser**

Welded to the body for a weather-tight seal. Provides excellent cosine response.

◆ **Detector**

An hermetically-sealed silicon photodiode.

◆ **Amplifier**

The amplifier converts the detector current into a 0 to +2.5V signal.

◆ **Cable**

The standard version of the sensor includes an attached 40' (12 m) standard cable. The industrial version includes a 16' (5 m) shielded cable. The Vantage Pro version comes with a 3' (0.9 m) standard cable.

MOUNTING HARDWARE

Please make sure you have all components listed below before continuing.

- ◆ Shield
- ◆ Body with cable attached
- ◆ Mounting hardware
Enables installation and leveling of the sensor.
 - ◆ Three #6-32 x 1-1/2" (38 mm) machine screws
 - ◆ Three springs
 - ◆ Three #6 flat washers
 - ◆ Three #6 screw retainers
 - ◆ Three #4 screw retainers
 - ◆ Three wood screws
 - ◆ One #8-32 x 3/4" (19 mm) machine screw
 - ◆ One #8-32 hex nut
 - ◆ One #8 flat washer
 - ◆ One 3/16" (5 mm) cable clamp

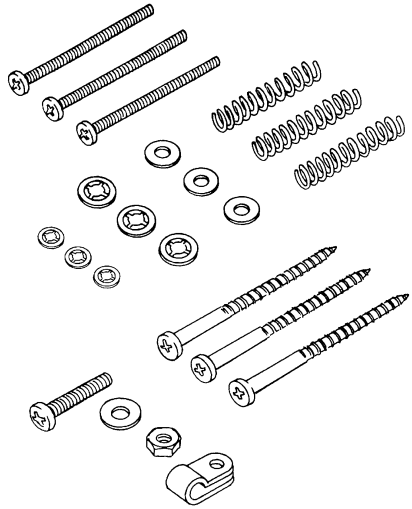

TOOLS AND MATERIALS NEEDED

You may need some of the following tools and materials in order to complete your installation. Please be sure you have everything you need before beginning.

- ◆ Medium Phillips screwdriver
- ◆ Scissors
- ◆ Center punch or nail (if mounting on wood surface)
- ◆ Drill with 7/8" (22 mm) and #36 (2.7 mm) drill bits (if mounting on wood surface)
- ◆ Wire cutters and stripper (industrial version only)

CONTENTS:

Standard and Industrial Versions: Installation.....	3
Testing the Sensor.....	3
Installing the Sensor.....	4
Typical Standard Installation.....	4
Typical Industrial Installation.....	5
Mounting on the Sensor Mounting Arm.....	6
Mounting on the Sensor Tilting Bracket.....	7
Mounting on a Wood Surface.....	10
Routing Sensor Cable.....	11
Vantage Pro Version: Installation on the Sensor Mounting Shelf..	12
Testing the Sensor.....	12
Accessing the SIM.....	12
Securing the Sensor on the Shelf.....	13
Routing Sensor Cable.....	14
If You Are Going to Install the Solar Radiation Sensor.....	15
Maintaining the Sensor.....	15
Technical Support.....	16

SPECIFICATIONS ARE AVAILABLE

For detailed technical information on the solar radiation sensor, call Technical Support (510) 732-7814 to request a specification sheet, or download it from our website:

<http://www.davisnet.com/support/weather/>

STANDARD AND INDUSTRIAL VERSIONS: INSTALLATION

Testing the Sensor

1. Attach the sensor cable to the connector S5 on the sensor interface module, or "SIM". Consult the System Installation manual for instructions
2. Press the appropriate key to make sure you are getting a solar radiation reading on the console.
Consult the station manual for instructions on displaying solar radiation.
3. Shade the sensor and make sure the reading changes.

Installing the Sensor

Follow the instructions in this section to install your sensor. Before you begin, consult the System Installation manual for instructions on labeling the sensor cable.

- ◆ For evapotranspiration (ET) or scientific measurements, the sensor can be mounted on the Sensor Mounting Arm (SMA) or any level surface.
- ◆ For measurements where the immediate effect on humans is of interest, we recommend that you mount the sensor such that its axis is aligned with the sun's rays at solar noon. This will maximize the mid-day readings and provide what is probably a more accurate measure of the solar radiation people are exposed to. The Health EnviroMonitor™ calculation of the solar radiation contribution to apparent temperature assumes that the sensor is tilted. The Sensor Tilting Bracket #7706 is designed for this purpose.
- ◆ Similarly, if you wish to predict or monitor the irradiance on a solar voltaic or thermal collection panel the data are probably most relevant if the sensor is tilted to the same angle as the collection panel. The Sensor Tilting Bracket #7706 is designed for this purpose.

Typical Standard Installation

The illustration below shows typical standard solar radiation installation. The sensor cable attaches to connector S5 on the sensor interface module (SIM).

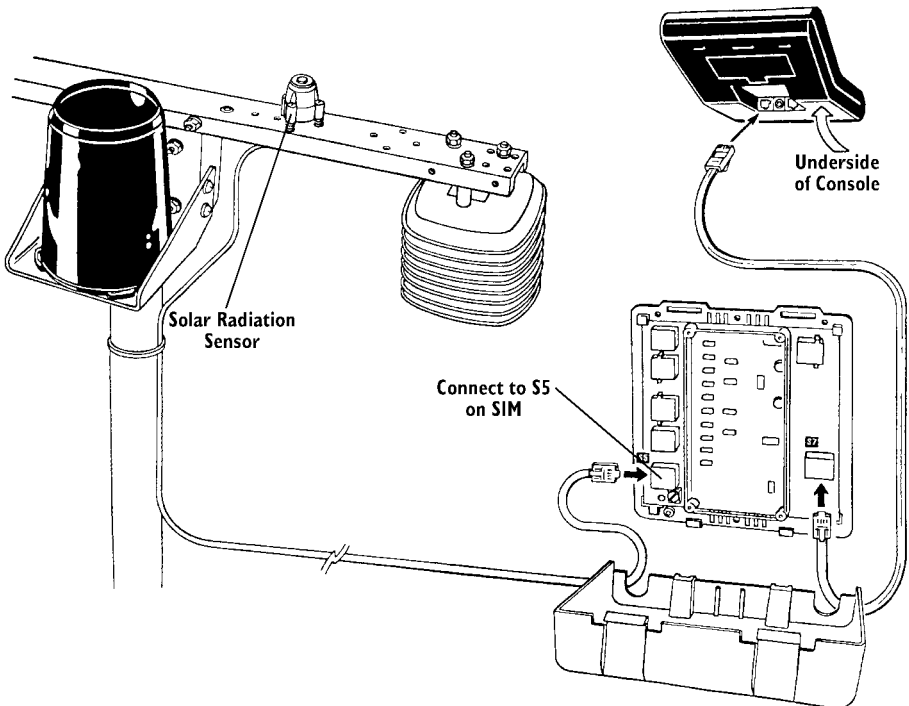

TYPICAL STANDARD INSTALLATION

Typical Industrial Installation

The illustration below shows typical industrial solar radiation installation. The sensor cable attaches to connector S5 on the sensor interface module (SIM).

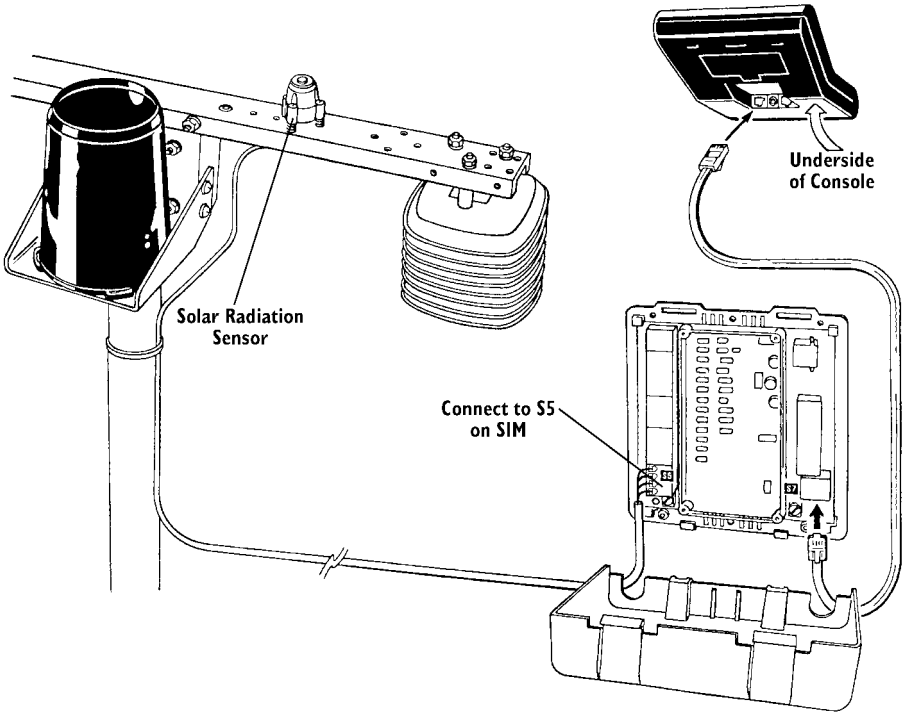

TYPICAL INDUSTRIAL INSTALLATION

Mounting the Sensor on the Sensor Mounting Arm

Follow the instructions below to mount the sensor on the Sensor Mounting Arm (SMA).

1. Route the cable through the large hole in the mounting arm if desired.
2. Place the shield onto the body as shown below.

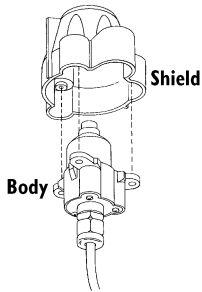

PLACING SHIELD ONTO BODY

3. Place a flat washer over the end of each screw and insert it into the body.
4. Place a spring over the end of each screw and hold the springs in place using a #6 screw retainer.
5. Secure the sensor to the mounting arm by driving the screws into the appropriate holes as shown below.

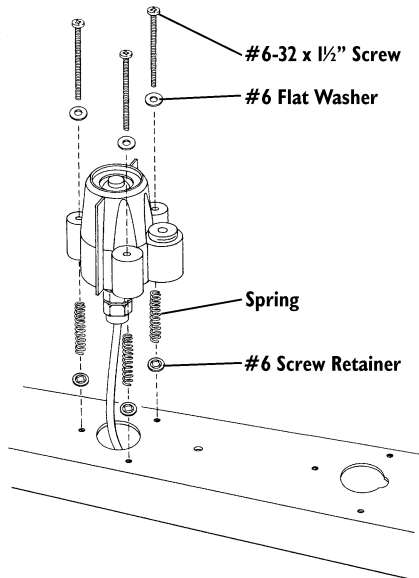

MOUNTING THE SOLAR RADIATION SENSOR ON THE SMA

6. Using the bubble level on the sensor as a guide, adjust the sensor until it is level by tightening or loosening the levelling screws as necessary.

-
7. Secure the sensor cable to the underside of the mounting arm using the 3/16" cable clamp, #8-32 x 3/4" screw, #8 hex nut, and #8 flat washer as shown below.

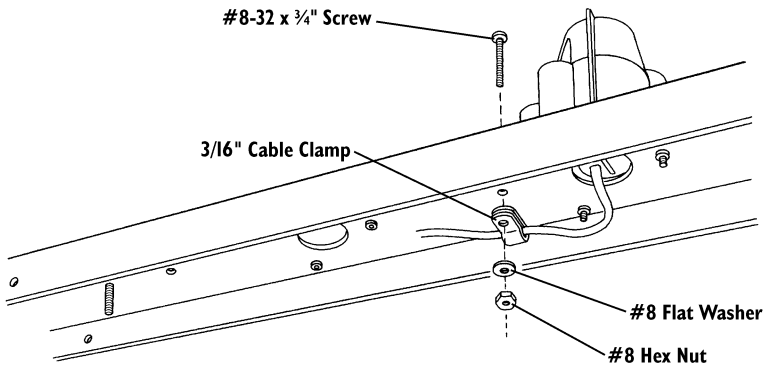

SECURING SENSOR CABLE

Mounting the Sensor on the Sensor Tilting Bracket

Follow the instructions below to mount the sensor on the Sensor Tilting Bracket. Do not install the bracket onto the mounting arm until instructed to do so below.

1. Route the cable through the large hole in the bracket if desired.
2. Place the shield onto the body as shown below.

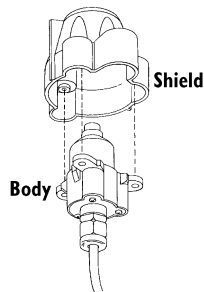

PLACING SHIELD ONTO BODY

3. Place a flat washer over the end of each screw and insert it into the body.
4. Place a spring over the end of each screw and hold the springs in place using a #6 screw retainer.
5. Secure the sensor to the bracket by driving the screws into the appropriate holes as shown below.

If mounting the sensor on the tilting bracket in a location under 46° latitude or in a situation which requires the angle of the tilting bracket to be less than 28°, you will need to use the standoffs supplied with the tilting bracket. Consult the Sensor Tilting Bracket manual for details.

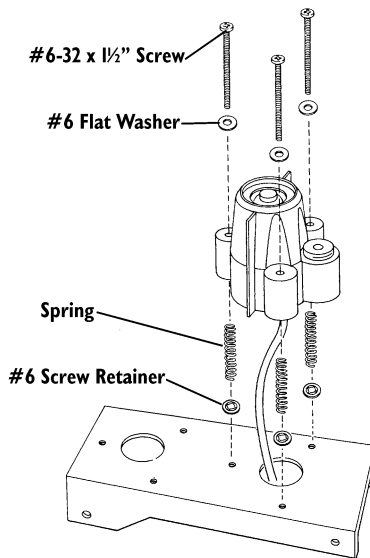

MOUNTING THE SOLAR RADIATION SENSOR ON THE SENSOR TILTING BRACKET

6. Position the Sensor Mounting Arm so it is pointed in the direction of the sun at solar noon.
Solar noon occurs halfway between sunrise and sunset; consult your local paper or the WeatherLink® software for sunrise and sunset times. To correctly align the arm, screw a mounting screw part way into any of the sensor's screw positions on the mounting arm and rotate the arm until the shadow from the screw is parallel to the edge of the sensor arm at solar noon.
7. Attach the bracket to the mounting arm as described in the Sensor Tilting Bracket instruction manual.
If you are installing both the solar radiation and the UV sensor on the sensor tilting bracket, make sure you mount the solar radiation sensor on the sensor tilting bracket before attaching to the sensor mounting arm.

8. If necessary, adjust the position of the sensor by tightening or loosening the levelling screws.

When pointed directly at the sun, the shadows from the alignment fins should appear as shown in the illustration below.

Step #1: Adjust side screws until fin shadows are equal.

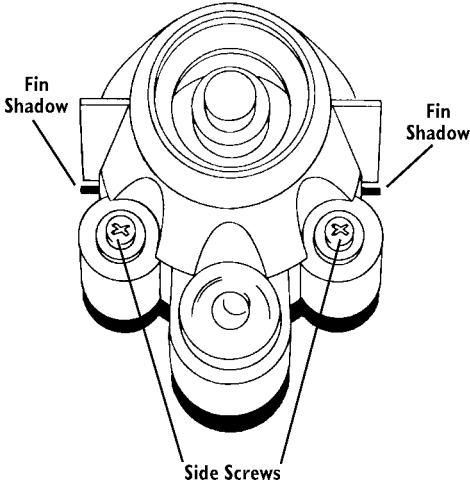

Step #2: Adjust back screw to minimize fin shadows.

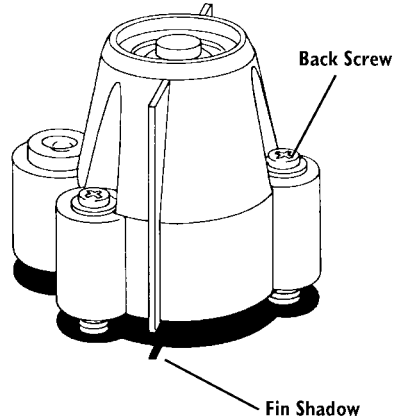

FINAL SENSOR POSITIONING

9. Secure the sensor cable to the underside of the mounting arm using the 3/16" cable clamp, #8-32 x 3/4" screw, #8 hex nut, and #8 flat washer as shown below.

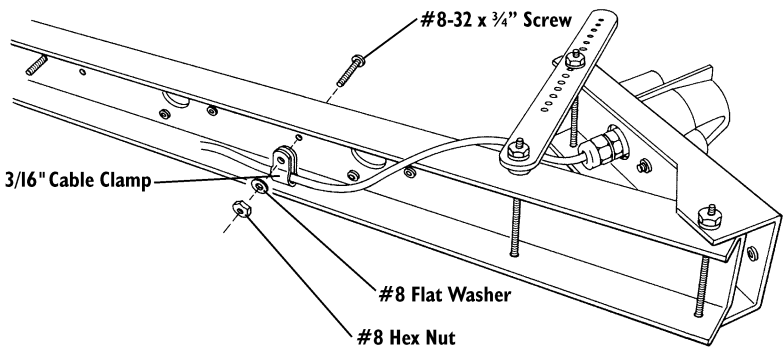

SECURING SENSOR CABLE

Mounting the Sensor on a Wood Surface

Follow the instructions below to mount the sensor on a wood surface.

1. Using the template printed at the bottom of this page, mark the location of the necessary pilot holes.
2. Using a drill with a #36 (2.7 mm) drill bit, drill pilot hole in the marked locations. If necessary, bore a hole through the mounting surface using a 7/8" (22 mm) drill bit so the bottom of the sensor can sit inside of it and the sensor cable can run to the other side.
3. Route the sensor cable through the hole in the wood if desired.
4. Place the shield onto the body as shown below.

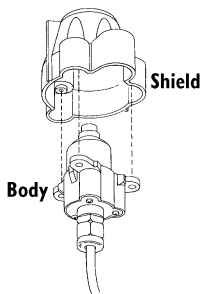

PLACING SHIELD ONTO BODY

5. Place a flat washer over the end of each screw and insert it into the body.
6. Place a spring over the end of each screw and hold the springs in place using a #4 screw retainer.

Use the template below to center-punch or mark pilot holes before drilling.

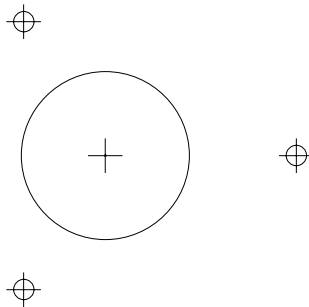

SOLAR RADIATION SENSOR MOUNTING HOLES TEMPLATE

-
7. Secure the sensor to the mounting surface by driving the screws into the appropriate holes as shown below.

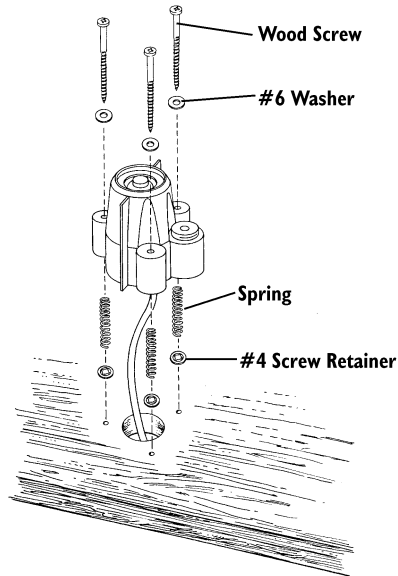

MOUNTING THE SOLAR RADIATION SENSOR ON A WOOD SURFACE

8. Using the bubble level on the sensor as a guide, adjust the sensor until it is level by tightening or loosening the levelling screws as necessary.
9. Secure the sensor cable to the mounting surface. You may use the provided 3/16" cable clamp, #8-32 x 3/4" screw, #8 hex nut, and #8 flat washer if possible.

Routing Sensor Cable

To prevent fraying or cutting of the cable where it is exposed to weather, secure it so it doesn't whip about in the wind. Use cable clips or weather resistant cable ties to secure the cable. Place clips or ties approximately every 3 to 5 feet (1 to 1.6 m). Do NOT use metal staples or a staple gun to secure cables. Metal staples—especially when installed with a staple gun—have a tendency to cut the cables.

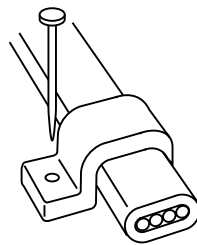

Cable Clip

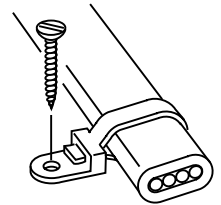

Cable Tie

Note: Try not to tug on the cable in such a way as to loosen the connections between cables. Also, make sure the sensor cable is not so taut that connections loosen or pull free due to the strain. Many sensor problems occur because cable connections come loose.

VANTAGE PRO VERSION: INSTALLATION ON THE SENSOR MOUNTING SHELF

Follow these instructions to mount the solar radiation sensor on the shelf. The shelf has two large holes, to hold a solar radiation sensor and a UV sensor. It doesn't matter which hole you use first.

Testing the Sensor

On Vantage Pro's Integrated Sensor Suite (ISS), the sensor interface module, or SIM, is inside the radiation shield. (The SIM is where the sensors connect with the rest of the weather station). You need to remove the radiation shield plates to access the SIM and test the sensor. Take your console with you.

On the rain collector side of your ISS, underneath the white mounting base is the radiation shield. It consists of several white plastic plates.

Accessing the SIM

1. Remove the wing nuts, lock washers and flat washers.
2. Remove the first three plates of the radiation shield. You should now be able to see the SIM.
3. Plug the solar radiation sensor cable into the receptacle labeled "SOLAR" on the SIM. Hold the sensor body with white diffuser pointed upward. Do NOT touch the diffuser. If you do, clean it after mounting. (See "Maintaining the Sensor" on page 15.)
4. On your console, press the "SOLAR" key to see reading. Shade the sensor with your hand — the value should drop.
5. Unplug the sensor cable from the SIM.

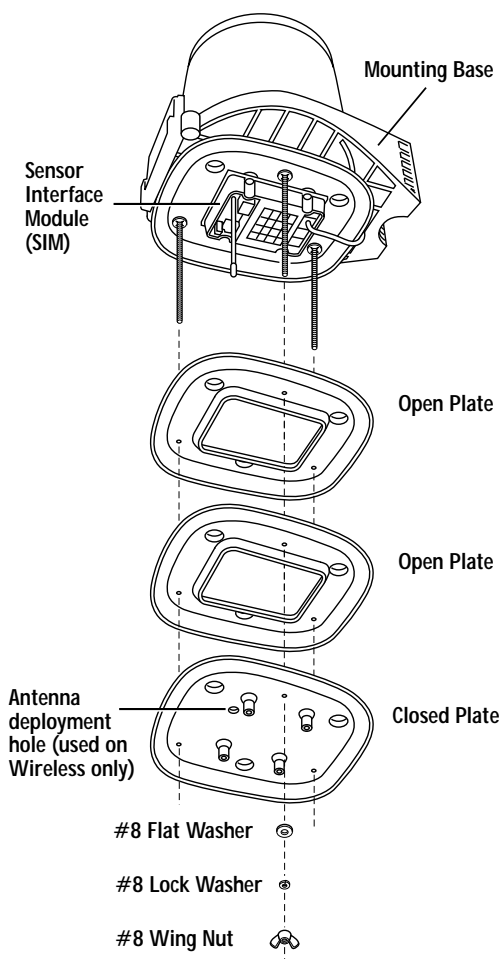

Do not put the shield plates back on yet. You'll have to plug the sensor cable into the SIM again, once you have mounted the sensor.

Securing the Sensor on the Shelf

1. Remove the rain collector cone: turn it counter-clockwise until the latches allow you to lift it up and off.
2. Place the shield onto the body as shown.
3. Route the sensor cable down through one of the large holes in the mounting shelf.

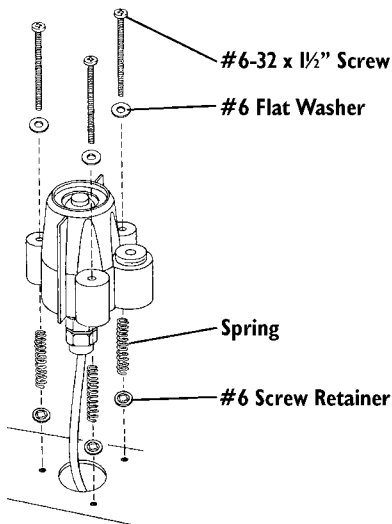
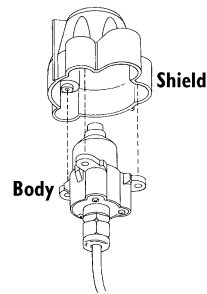

4. Place a flat washer over the end of each screw and insert it into the body.
5. Place a spring over the end of each screw and hold the springs in place using a #6 screw retainer.
6. Secure the sensor to the mounting shelf by driving the screws into the appropriate holes as shown.
7. Using the bubble level on the sensor as a guide, adjust the sensor until it is level by tightening or loosening the screws as necessary.

Note: Final leveling of the sensor(s) should be done with the ISS mounted in its operating location.

Routing the Sensor Cable

You will route the sensor cable through the base of the rain collector and out through a hole, then connect it to the SIM inside the radiation shield. (This step requires that the radiation shield is open. If it is not, remove the shield plates now as shown in “Accessing the SIM” on page 12.)

See the illustration below as you follow these instructions.

1. Tie the sensor cable to the shelf support tube.
Use one of the plastic 4" cable ties provided with the sensor mounting shelf to keep the cable in place. (#1 in illustration.)
2. Squeeze the cable down into the cable notch on the circular edge of the rain collector base. The cable needs to be wedged down into the notch so it will come up inside the rain collector cone when the cone is put back on.
3. Route the cable down and out through the hole in the base.
Plug the cable into the receptacle labeled “SOLAR” in the SIM, to see how much slack will be left in the cable as you secure it inside the rain collector.
4. In the rain collector base, loop up the slack in the cable. Using the two cable clamps in the base, secure one loop.
Tie the remaining loops of cable together with cable ties #2 & 3 as shown.

When securing the sensor cable(s) inside the rain collector base, the goal is to **ensure that the cables do not interfere with the tipping bucket mechanism** of the rain collector.

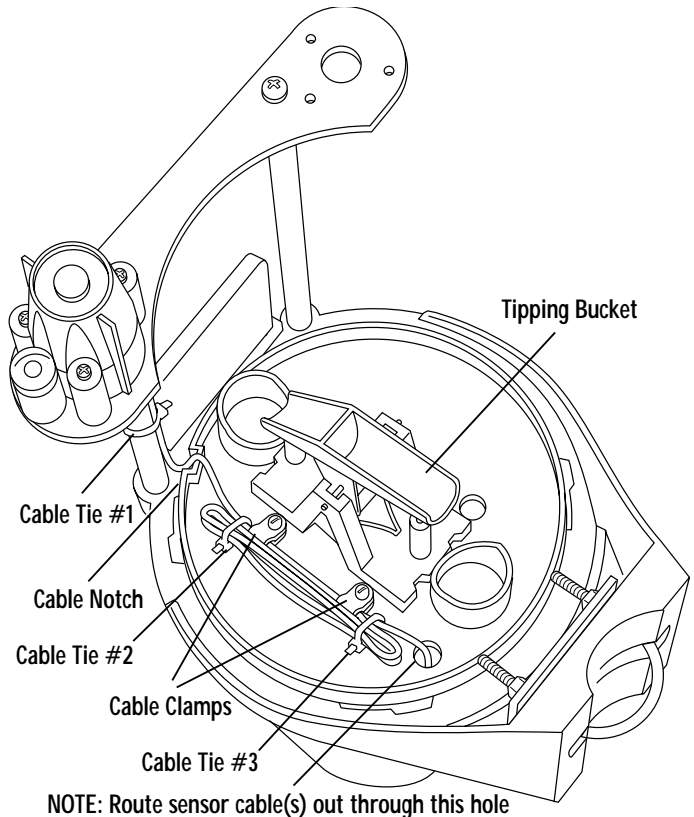

-
5. Cut off the ends of the cable ties.
 6. Put the rain collector cone back on the base, turning it clockwise until the latches hold it in place. Be sure that it does not squeeze the sensor cable where it goes down into the notch and up inside the cone.
Don't put the cone back on if you're going to install the UV sensor at this time.
 7. Clean the sensor as instructed in "Maintaining the Sensor" on page 15.

If You Are Going to Install the UV Sensor

If you're installing the UV sensor also, use the same testing and installation procedure just completed for the solar radiation sensor. In the rain collector base, the cable clamps have room to secure one loop of the UV sensor cable and one loop of the solar radiation sensor cable.

Reassembling Radiation Shield

Consult the illustration on page 12.

1. Slide the two open plates over the threaded studs.
2. Slide the single closed plate over the threaded studs.
3. Place a flat washer, lock washer and wing nut over one of the studs.
Tip: temporarily place a wing nut on one of the studs to hold the plates as you place washers and a wing nut on another stud.
4. Finger-tighten the wing nut.
5. Repeat #3. and #4. until all three wing nuts are secure.

MAINTAINING THE SENSOR

For the most accurate readings, clean the diffuser after mounting, and then periodically. Use ethyl alcohol (NOT rubbing alcohol) or water with a little detergent in it.

Due to the sensitivity of solar radiation sensors it is common practice for manufacturers to recommend re-calibration after a period of time. Here at Davis Instruments we have seen approximately 2% drift per year on the readings from these sensors. For applications demanding higher accuracy, the sensors should be calibrated once every year.

Contact Technical Support (510) 732-7814 about returning your sensor for calibration.

TECHNICAL SUPPORT

Before calling Technical Support (510) 732-7814 regarding a problem with your sensor, carefully check all cable connections from the sensor to the console. Cable connections account for a large portion of the potential problems. Connections should be firmly seated in the jacks and plugged in straight. If you think a connection may be faulty, try jiggling the cable while looking at the display. If a reading appears intermittently on the display as you jiggle the cable, the connection is faulty.

Product Numbers: 7821, 7823, 6450

Davis Instruments Part Number: 7395.092
Solar Radiation Sensor, Standard, Industrial & Vantage Pro versions
Rev. C Manual (1/12/01)

This product complies with the essential protection requirements of the EC EMC Directive 89/336/EC.

Copyright ©2000 Davis Instruments Corp. All rights reserved.

DAVIS 
Davis Instruments

3465 Diablo Avenue, Hayward, CA 94545 U.S.A.